



3 GHz SMA LATCHING S.P.4 T. SWITCH

OPTIONS :

**R F CHARACTERISTICS**

NUMBER OF WAYS : 4  
 FREQUENCY RANGE : 0 - 3 GHz  
 IMPEDANCE : 50 Ohms

FREQUENCY (GHz)	0 - 3
V.S.W.R <=	1.20
INSERT. LOSS <=	0.20 dB
ISOLATION >=	80 dB
AVER. POWER (*)	240 W

**ELECTRICAL CHARACTERISTICS**

ACTUATOR : LATCHING  
 NOMINAL CURRENT AT 25° C (±10%) : 320 mA / RESET : 1280 mA (\*\*)  
 ACTUATOR VOLTAGE (Vcc) : 12V (10.2 to 13V) / NEGATIVE COMMON  
 TERMINALS : solder pins (250°C max./30 sec.)

**MECHANICAL CHARACTERISTICS**

CONNECTORS : SMA female per MIL C 39012  
 LIFE : 5.000.000 cycles per position  
 SWITCHING TIME (nominal voltage;25° C) : < 15 ms  
 CONSTRUCTION : splashproof  
 WEIGHT : < 180 g

**ENVIRONMENTAL CHARACTERISTICS**

OPERATING TEMPERATURE RANGE (°C) : -40 , +85  
 STORAGE TEMPERATURE RANGE (°C) : -55 , +85

(\* : average power at 25° C per RF path)  
 (\*\* RESET : supply voltage time 1sec. max./duty cycle 10%)

4112-9212 This information is given as an indication. In the continual goal to improve our products, we reserve the right to make any modifications judged necessary

4113-9212 This information is given as an indication. In the continual goal to improve our products, we reserve the right to make any modifications judged necessary

**DRAWING**

General tolerance: ± 0,5 mm

**R573 322.400**

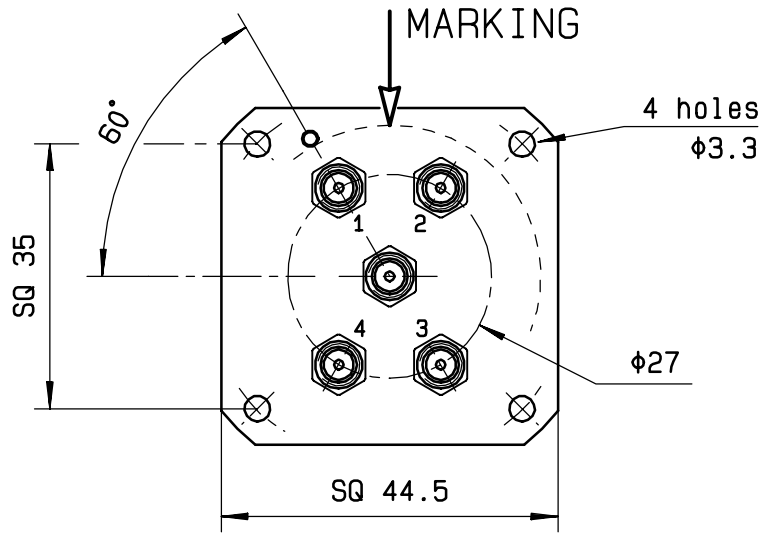

Voltage	RF continuity
-C +RESET	All ports open
-C +1	IN ↔ 1
-C +2	IN ↔ 2
-C +3	IN ↔ 3
-C +4	IN ↔ 4

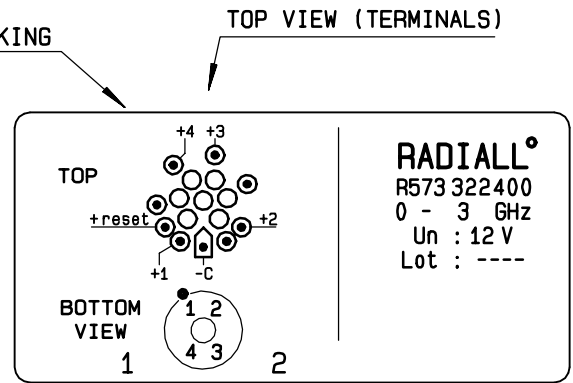
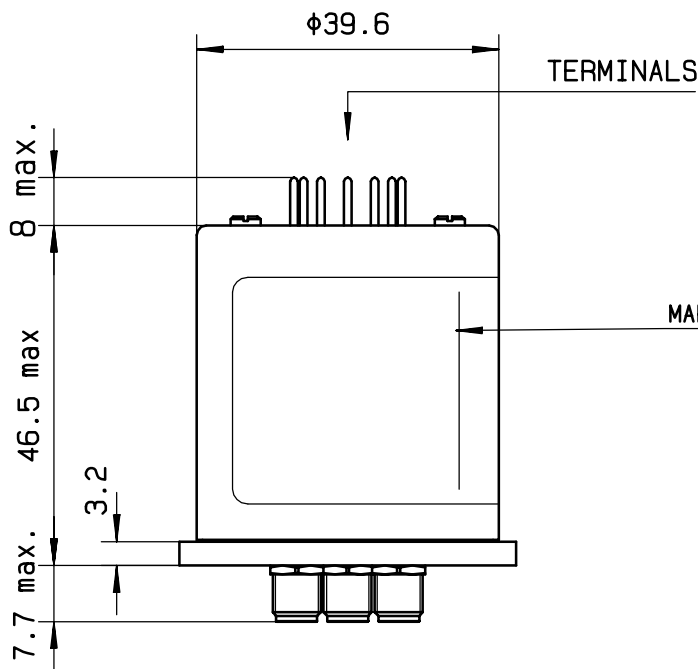

**RADIALL<sup>o</sup>**  
R573 322400  
0 - 3 GHz  
Un : 12 V  
Lot : ----

**SCHEMATIC DIAGRAM**

